

POMPA PER VUOTO LUBRIFICATA A PALETTE OIL-LUBRICATED ROTARY VANE VACUUM PUMP

12PBO-M

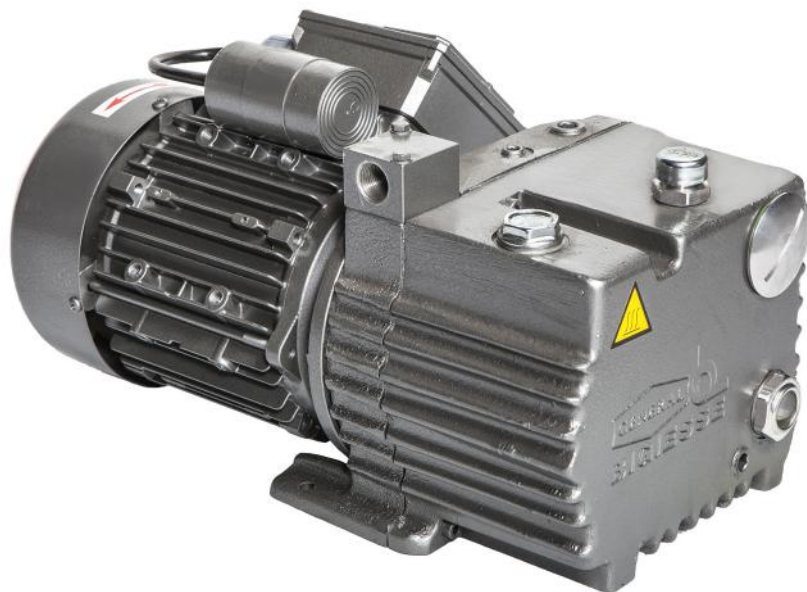

Gruppo pompante in ghisa accoppiato direttamente al motore elettrico. Separatore aria/olio in alluminio per l'eliminazione di nebbie d'olio in mandata, valvola di ritegno in aspirazione, raffreddamento ad aria. Prima carica olio inclusa.

Cast iron compressor pump coupled directly to the electric motor. Aluminium oil/air separator eliminates oil mist discharge, suction check valve, air cooling. First oil filling included.

Accessori : Filtro aria, valvola zavorra gas, vacuometro, Fluido sintetico atossico BGS TORR F32®
Tensioni speciali : 12 Vcc / 24 Vcc / UL-CSA

Accessories : Air filter, gas ballast valve, vacuum gauge, BGS TORR F32® non-toxic synthetic fluid
Special voltages: 12 Vcc / 24 Vcc / UL-CSA

SPECIFICHE / SPECIFICATIONS

(I) (F)	(GB) (E)		PBO		PBOM	
			50Hz	60Hz	50Hz	60Hz
Portata nominale Débit nominal	Nominal capacity Caudal nominal	m ³ /h *	12	14,4	12	14,4
Pressione finale (ass.) Presión final (abs.)	Ultimate pressure (abs.) Vide final (abs.)	mbar * hPa *	10		0,5	
Potenza motore Puissance moteur	Motor power Potencia motor	Kw - 3 ~	0,37	0,37	0,37	0,37
		Kw - 1 ~	0,37	0,37	0,37	0,37
Numero di giri Número de révolutions	Revolutions number Velocidad de giro	min. ⁻¹	2.750	3.300	2.750	3.300
Max pres. di asp. per vapore H2O Pression max. d'entrée pour la vapeur d'eau	Max inlet pressure for water vapour Presión máx. admisible del vapor de agua	mbar hPa	40	40	40	40
Max q.tà vapore d'acqua Débit de pompage max de vapeur d'eau	Max water vapour pumping rate Cantidad máx. vapor de agua	Kg/h	0,3	0,3	0,3	0,3
Livello di pressione acustica Niveau de pression acoustique	Sound pressure level Nivel de presión acústica	dB(A)*	65	67	65	67
Carica olio Charge d'huile	Oil charge Carga de aceite	L	0,25			
Peso totale Poids total	Total weight Peso total	Kg	14	14	14	14

* = tolleranza / tolerance / tolérance / tolerancia ±10%



BGS GENERAL srl
Via Zibido, 3 - 20080 Zibido San Giacomo (MI) - Italy
+39 02.90005069 r.a. - bigiesse@bigiesse.it - www.bigiesse.it

E0_R0

POMPA PER VUOTO LUBRIFICATA A PALETTE OIL-LUBRICATED ROTARY VANE VACUUM PUMP

3D

12PBO-M



DIMENSIONI / DIMENSIONS

	mm
A*	320
B	144
C	176
D	155
E	13
F	23
G	165
H*	165
L	36,5
M	181
Øa	3/8" G
Øp	7
X	149
Y	138

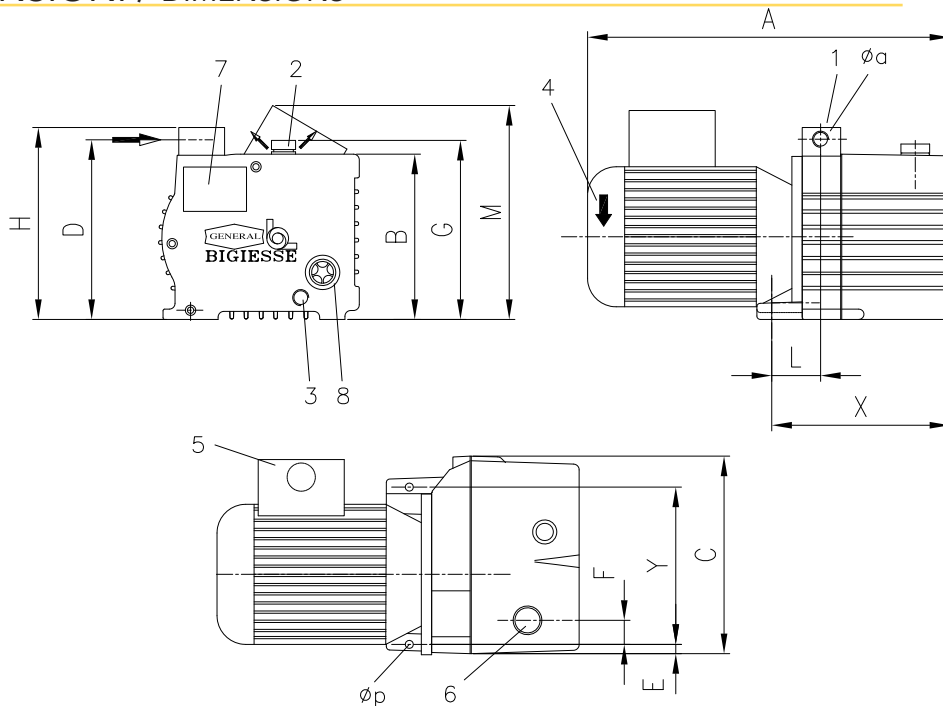

1	Valvola di aspirazione	Suction valve	5	Morsettiera	Wiring box
2	Scarico aria	Exhaust	6	Tappo riempimento olio	Oil filler
3	Scarico olio	Oil drain	7	Targhetta dati	Data plate
4	Freccia senso di marcia	Rotation arrow	8	Spia livello olio	Oil control

* = Le quote A e H possono subire variazioni / The dimensions A and H as well as the current drawn can differ - Salvo modifiche tecniche / We reserve the right to alter technical information

PRESTAZIONI / PERFORMANCE CURVE

PBO

PBOM

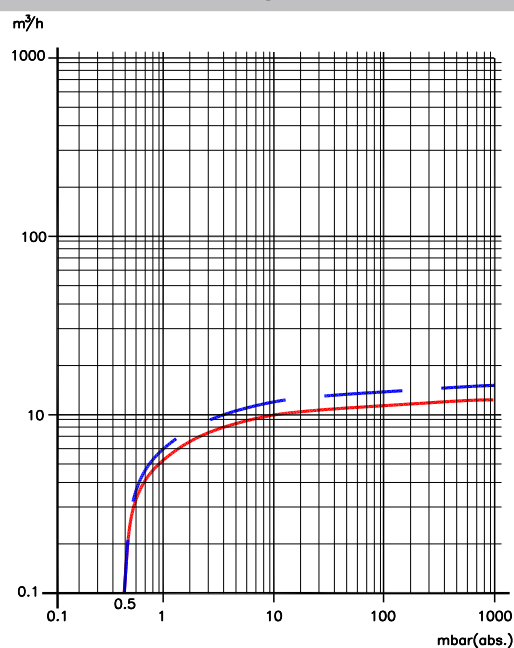
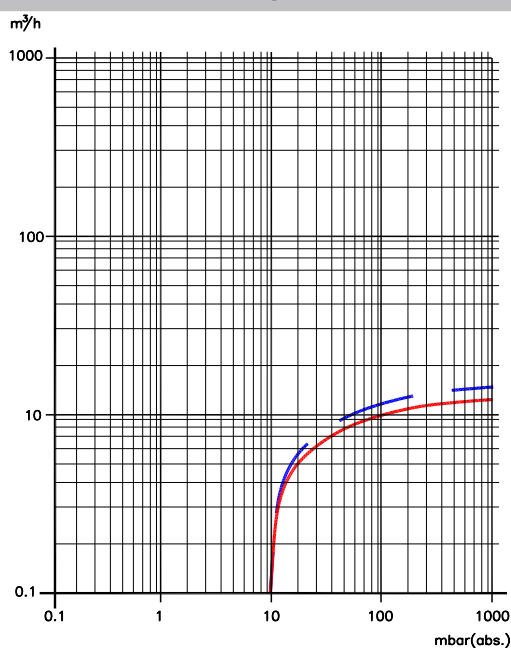
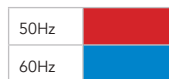

Curve riferite alla pressione di aspirazione e temp. 20°C (tolleranza ±10%). / Curves refers to inlet pressure and 20°C temp. (tolerance ±10%).

BGS GENERAL srl

Via Zibido, 3 - 20080 Zibido San Giacomo (MI)

+39 02.90005069 r.a. - bigiesse@bigiesse.it - www.bigiesse.it



E0_R0